

Atlanta™ Product Family.....

- High Performance Router
- Integrated 200 MHz MIPS Processor and 200 MHz Voice DSP
- Robust Voice/Firewall/VPN/Router Stack
- Hardware Encryption Accelerator
- Hardware Packet Acceleration Engine
- Enhanced IPQoS
- PCI WiFi Ready
- Two 10/100 Ethernet MAC interfaces (enables port based DMZ)

The Atlanta™ Product Family addresses the needs of telecommunication operators and service providers by enabling them to differentiate their offerings through superior voice-quality and next-generation telephony features, while outlining a roadmap that enables a smooth transition to the fully-integrated VoIP network of the future. The level of voice-quality and features incorporated into the Atlanta Product Family enables service providers to increase their revenue opportunities by offering consumers a toll-quality VoIP experience with advanced features such as global phone number portability, virtual phone numbers, iron clad security, superior echo cancellation and a host of other new features not available with traditional phone service. In turn, consumers will be able to enjoy the benefits of economical, go-anywhere telephony combined with a wide variety of powerful calling features.

System Architecture

The Atlanta Product Family is a highly integrated product family that combines a management processor, a voice engine, and a data engine specifically designed for residential gateways, MTA (media terminal adapter), and IADs (integrated access devices). Its design integrates a high-performance network processor, two RMII interfaces, a voice DSP (digital signal processor), a USB interface, and dual PCM/IOM2 interfaces.

Integrated Network Processing

An integrated RISC processor (network processor) performs initialization, network management, data routing, NAT/PAT, and other functions. The system includes extensive DMA resources and an efficient memory controller that supports from 8-Mbytes up to 32-Mbytes of 100-MHz SDRAM. To minimize network-processing overhead, the hardware DMA controllers include state machines that work directly with high-level data structures (packet descriptor queues).

Voice Functionality

The Atlanta Product Family integrates a DSP core for voice processing. The DSP core has four execution units with VLIW (very-long instruction word) architecture, an 8-Kbyte Instruction-cache, a 16-Kbyte Data-cache, and is supported by DMA and hardware messaging facilities. The DSP firmware is included with extensive voice compression and processing capabilities. The software library for the Family provides a rich set of APIs for DSP, QoS, and full-suite RTP/RTCP protocol stack.

VPN Functionality

The Atlanta 100 device can manage VPNs (virtual private networks). It is a scalable solution that requires limited configuration on the nodes that make use of the VPN for exchanging data.



the edge in broadband™

The Atlanta 100 device supports the following three major VPN modules:

- IPSec (Internet protocol security)
- IKE (Internet key exchange)
- L2TP (Layer 2 tunneling protocol for VPNs)

The IPSec module supports DES, 3DES, and AES encryption, as well as SHA1 and MD5 hashing in hardware.

Packet Header Processor

The PHP (packet header processor) assists the network processor by off-loading many of the routine packet pre-processing tasks. Many of these packet pre-processing tasks are not only done faster, but are done using an independent packet processor, which frees up CPU cycles.

Physical Interfaces for Applications

The Atlanta Product Family integrates two 10/100 Ethernet MAC ports with standard RMII interfaces (one configurable MII interface for one MAC is also available). These ports enable the devices to interface with any other LAN PHY device that is compatible with the RMII standard interface. The network processor manages the receive and transmit queues, and the routing between the Ethernet ports. The device provides two selectable IOM or PCM highway interfaces (60 timeslots) for voice processing and TDM (time-division multiplexing) interfaces. The Atlanta Family's DSP core voice-engine can tap into any combination of timeslots. The Atlanta Product Family provides a dual-mode host bus that can interface with both PCI and PC Card peripheral devices. Most 802.11a, 802.11b, and 802.11g devices can be interfaced directly to Atlanta devices with zero glue logic. The chip contains a fully integrated USB version 1.1 device interface.

32-bit PCI and 16-bit PCMCIA Interface

The Atlanta Product Family provides a shared address, data bus, and dedicated control signals for both the PCI Cardbus and PCMCIA. The Family also supports up to 16 MB of 16-bit parallel flash memory.



CENTILLIUM COMMUNICATIONS

Disclaimer: This document contains information on a product under development at Centillium Communications, Inc., and is intended to help you evaluate this product. Centillium Communications reserves the right to change or discontinue work on this proposed product without notice. Trademarks: Centillium, eXtremeDSL, CopperFibre, Maximus, Palladia, Entropia, Zeus, Apollo, Unicorn, Mustang, Colt, Atlanta, Pharos and the Centillium Logo are trademarks of Centillium Communications, Inc., in the United States and/or other countries. The names and logos of actual companies and/or products mentioned herein may be the trademarks of their respective owners.

Atlanta™ Product Family

Features

Atlanta™ Product Family integrates

- Network processor
- Voice DSP and codec
- Packet acceleration engine
- Hardware AES, DES, and 3DES encryption engine
- VPN
- PCI
- USB
- Network interfaces (two Ethernet MACs)

Data support

- Integrated RISC processor: 200 MHz MIPS with 16-Kbytes instruction cache, 8-Kbytes data cache, 32-Kbytes boot RAM, and MMU
- Hardware AES, DES, 3DES, MD5, and SHA-1 encryption engine
- Two 10/100 Ethernet MAC interfaces with standard RMIII
- USB 1.1 slave interface
- Hardware traffic shaping for eight VCCs
- Packet-level traffic shaping as well as classification and marking for IPQoS support
- Packet header co-processor with ingress queuing for fast incoming traffic preprocessing and TCP/IP functionality offload as well as IPQoS
- Hardware support for VCC demultiplexing ATM
- RFC 1483/RFC 2684 (routing or bridging; LLC or VC multiplexing)
- PPP-over-ATM (RFC 2364)
- CBR/UBR/ABR with PCR Shaping/VBR-rt/VBR-nrt
- Eleven VCCs supported in hardware, additional VCCs supported in software
- I.610 OAM F4/F5 loopback/AIS/RDI/continuity check
- ILM1 and support for TR037
- RFC1577/RFC 2225 (classical IP over ATM) data networking and management
- SNMP v1/v2 (ADSL/ATM/MIB2)
- NAPT with over 50 ALGs
- TCP/IP with RIP1 and RIP2 (RFC 1058, RFC 1389)
- DHCP server and client (RFC 2131)/DHCP relay
- DNS
- Stateful inspection firewall
- Integrated VPN and firewall for highest performance and security
- PPPoE (RFC 2516)
- PPP (RFC 1661, RFC 1144)
- 802.1d transparent bridging protocol
- Embedded http server
- FTP server/client
- TFTP client/server
- SNTp protocol
- IGMP proxy (v1/v2/v3)
- Bootp
- Telnet
- SMTP/log/onboard flash log

Voice features

- Integrated DSP Processor: VLIW architecture 200 MHz voice DSP supports up to four channels of deep compression codecs
- Supports one FXO and four FXS channels
- G.711 (PCM), G.729a/b, G.726-32, and G.723.1 AMR narrowband codes
- Supports generic VAD (voice activity detection) and CNG (comfort noise generation)
- G.711 fax/modem pass-through (fax/modem detection and reversion to PCM 64 kbps)
- Supports caller ID, including JCLIP

Devices and Applications

| | 1 WAN, 2 FXS | 1 WAN, 1 LAN, Router, 2 FXS | 1 WAN, 4 Port Switch, 2 FXS, WIFI PORT | 1 WAN, 1 LAN Router, 4V FXS | 1 WAN, 1 LAN, Router/ Encryption/ Firewall, 4V FXS |
|------|--------------|-----------------------------|--|-----------------------------|--|
| A70 | ● | ● | | | |
| A80 | | | ● | | |
| A90 | | | | ● | |
| A100 | | | | | ● |

- Supports call forwarding and call waiting
- G.168 echo cancellation with programmable echo tail length from 8-28 ms
- DTMF tone generation and detection Q.21/Q.23/Q.24
- Adaptive and configurable jitter buffer with maximum size of 300 ms
- T.38 Fax Relay
- Message waiting indicator and call hold
- Pulse dialing
- Dual FXS or FXS/FXO modes
- Meets G.711-G.712 and wideband G.722.2 ITU-T requirements
- Programmable ring generation
- Integrates two comparators with programmable hysteresis and threshold for line monitoring
- Ring and hook detection circuit
- Polarity reversal detection
- Record and play announcements per channel

Interfaces and memory

- 16-bit PC Card and 32-bit PCI
- SPI interface with four chip selects for serial, flash, Ethernet switches, and SLIC/SLACs
- PCM/IOM2 interface with programmable time slots
- Boot loading and configuration using either parallel flash on PC Card bus, serial flash on SPI bus, or external host on PCI bus
- Supports 8-, 16-, or 32-M bytes of SDRAM
- Support for 16/32-bit wide SDRAM memory
- Two integrated Ethernet MACs with industry standard RMIII interface
- USB 1.1 slave

Atlanta Product Family Block Diagram

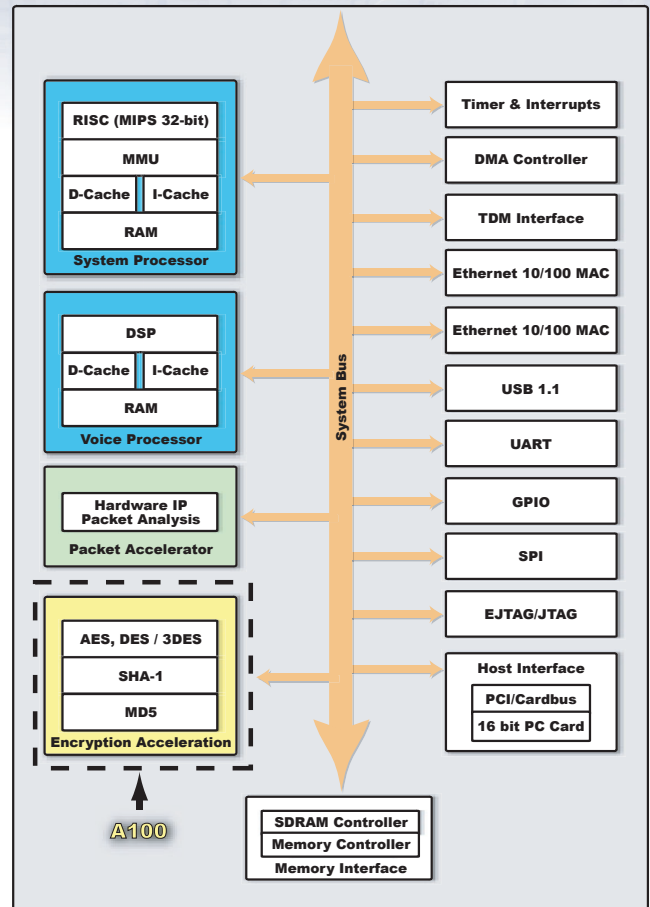

215 Fourier Avenue
Fremont, CA 94539

TEL: (510) 771-3700
FAX: (510) 771-3500

EMAIL: info@centillium.com
WEB: www.centillium.com